

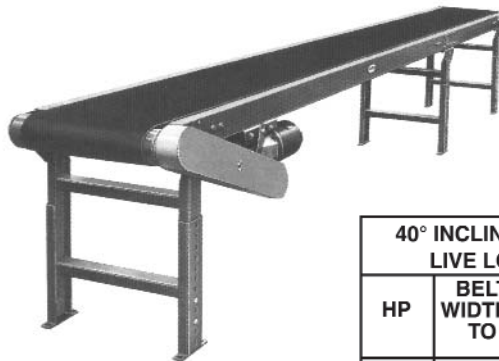

Hytrol Horizontal Belt, Inclined and Portable Conveyors

Over the years, the name Hytrol has become synonymous with quality conveying systems. Hytrol makes over 70 powered conveyor models, a complete line of gravity conveyors and many types of conveyor accessories. The model TA horizontal can be used in most situations. The model C incline belt handles bags, boxes and cartons. It may be set at any angle from horizontal to 45 degrees for various uses, including floor-to-floor conveying. The portable model BA's one-lever control adjusts angle without effort. A powered screw locks in the desired angle.



STANDARD FEATURES:

- Easy setup to save installation time
- Adjustable floor supports
- Many widths and load capacities
- Wide choice of belt styles
- Very customizable
- Bed section folds (portable conveyors)

40° INCLINED SLIDER BED CONVEYOR LIVE LOAD CAPACITY @ 65 FPM				
HP	BELT WIDTHS TO	LENGTHS UP TO		
		20'	30'	46'
DISTRIBUTED LOAD (LBS.)				
3/4	14"	180	175	165
	18"	175	170	155
	24"	170	155	140
1	14"	250	240	230
	18"	245	235	220
	24"	240	225	205
1 1/2	14"	385	375	365
	18"	380	370	355
	24"	375	360	340
2	14"	520	515	500
	18"	515	505	490
	24"	510	495	475

LOAD CAPACITY CHART HORIZONTAL SLIDER BED CONVEYOR @ 65 FPM W/STANDARD BELT								
HP	BELT WIDTHS TO	LENGTHS UP TO						
		4" Dia Drive Pulley					8" Dia Drive Pulley	
		11'	21'	31'	41'	51'	77'	102'
DISTRIBUTED LOAD (LBS.)								
1/2	16"	335	320	310	300	285	260	230
	24"	320	300	285	270	255	210	170
	30"	300	275	255	235	215	165	115
3/4	16"	515	505	495	480	470	440	415
	24"	500	485	470	455	435	395	355
	30"	485	460	440	420	400	350	300
1	16"	650	635	625	615	605	625	595
	24"	635	620	600	585	570	580	540
	30"	620	595	575	550	530	535	480



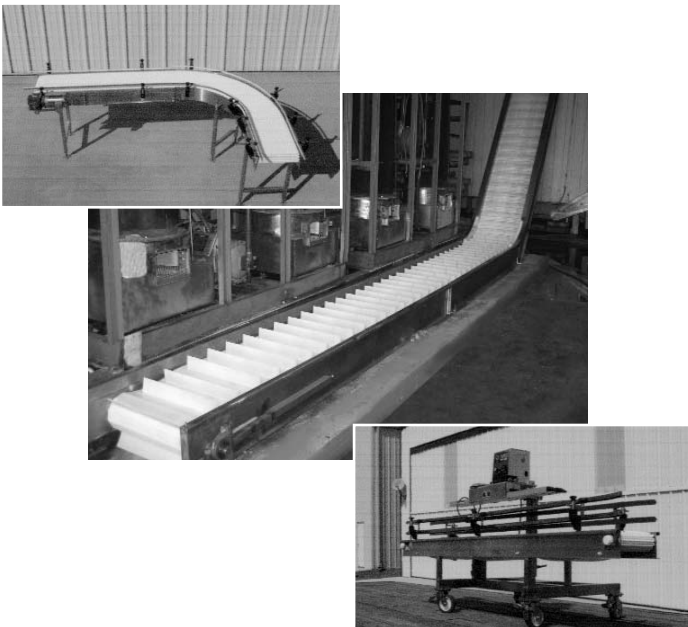

Industrial Conveyor Fabrication

Industrial Conveyor & Fabrication, Inc. specializes in the design and fabrication of custom conveying equipment. With a total of **over 50 years combined experience**, they have designed and built many conveyor systems for the food, and non-food industries.



Matthiesen Belt Conveyor

A very rugged 10"-wide by any length belt that is ideal for moving ice bags. Can be inclined and side walls are available.

STANDARD FEATURES:

- Galvanized body construction (Stainless steel available)
- Adjustable from 12" to 40" from top of belt to floor
- Standard with casters (4" wheel)
- Belting is a brown, rough top with stainless lacing
- FDA-approved belting is available
- 3/4 HP up to 14 feet; 1 HP for longer belts
- 60-62 feet per minute standard
- 116/1/60 (50 HZ available), 4.6 amps



Matthiesen Bucket Elevators

This unit creates a new opportunity for plants with limited space and can replace a vertical screw. Compared to other conveyor systems, the bucket conveyor reduces product damage. All are custom made to meet your plant's specifications. These units require less HP to operate than screw conveyors.

STANDARD FEATURES:

- All Stainless steel construction
- UHMW polyethylene bucket belt
- 24"-wide moves 7 tons per hour
- 36"-wide moves 13 tons per hour
- Wash-down motors and gear reducers
- Stainless ball bearings
- FDA approved materials





CONVEYORS

Martin and Custom Screw Conveyors

Stainless steel and galvanized steel conveyors are available for horizontal, incline, dewatering and snow removal applications. You'll get the right system to solve your unique situation while keeping costs at a minimum. Martin manufactures the most complete line of stock components in the industry. Standard sizes from 6" to 16".

Stock Screw Conveyor Components



Martin manufactures the most complete line of stock components in the industry. We stock stainless, galvanized, and many other items that are special order with others in the industry.



SCREW CONVEYORS

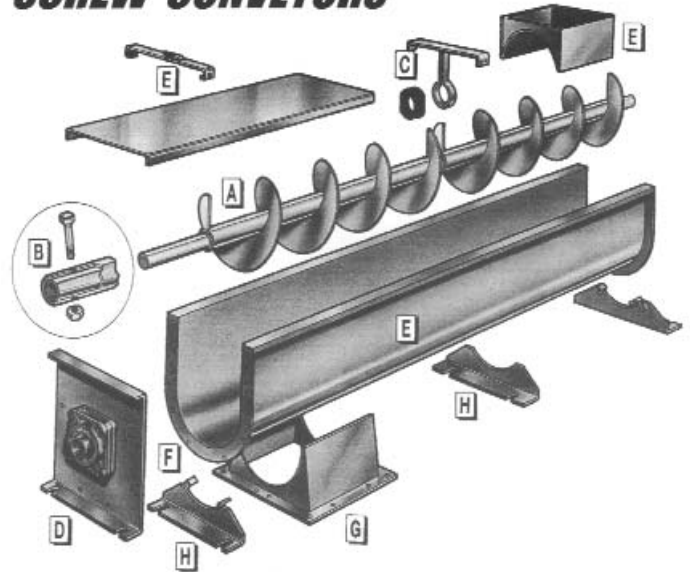

- A. Conveyor Screw
- B. Jig Drilled Couplings
- C. Hangars and Bearings
- D. Trough Ends
- E. Troughs, Covers, Clamps and Shrouds
- F. Flange
- G. Feed and Discharge Spouts
- H. Supporting Feet and Saddles

Matthiesien Screw Conveyor Systems

These screws are designed to meet your requirements. The types available are horizontal, vertical, incline and portable in 6", 9", 12", 16" or larger diameters. Screw conveyors can be ordered either as complete units or by individual components. Complete units are assembled, pre-tested, marked and disassembled prior to shipment. Components-only orders must be sorted out and aligned during field assembly.

STANDARD FEATURES:

- Galvanized construction (304 stainless, food-grade finish available)
- All joints have gaskets
- All UHMW is FDA approved
- Dodge drives are standard
- Completely customizable
- Flat, shroud, hinged and Plexiglas covers are available

